

GelCool Systems

Warming/Cooling System for Hard Hats

Maximize Productivity, Concentration,
Safety, and Comfort

Quick Change Gel Pack System for the
Workplace

Maintain Hard Hat Protection While
Providing Significant Cooling or Warming
Benefit to Users

Protect Your Most Significant Assets, Your
Employees

GELCOOL GEL PACK IN A STANDARD HARD HAT



GELCOOL TWO-STAGE COOLING SYSTEM

GelCool Systems provides a complete, modular system for hard hat warming and cooling in the workplace, which includes a specialized portable freezer/warmer and our proprietary gel packs. This system is easily managed and maintained. We use a two-stage cooling system in our gel packs. Since there is very little passive airflow through hard hats, we use the empty space above the user's head for storage of our main cooling source, the core coolant pack. We use a highly stable, non-toxic gel in the core coolant pack to provide a predictable, long-term cooling (or warming) source. This gel is stored in a coolant reservoir that is bonded to a larger skull cap called the thermal distribution layer. The core coolant pack is specifically designed to align with each major hard hat manufacturer's existing suspension straps. The thermal distribution layer serves three purposes: uniform distribution of cooling over the entire cranial contact surface; a platform for carrying and aligning the core coolant pack; a comfortable user interface via the soft fabric bottom layer (helping to avoid a sudden surge of cooling to the head).

GELCOOL SYSTEMS PORTABLE WARMERS AND COOLERS

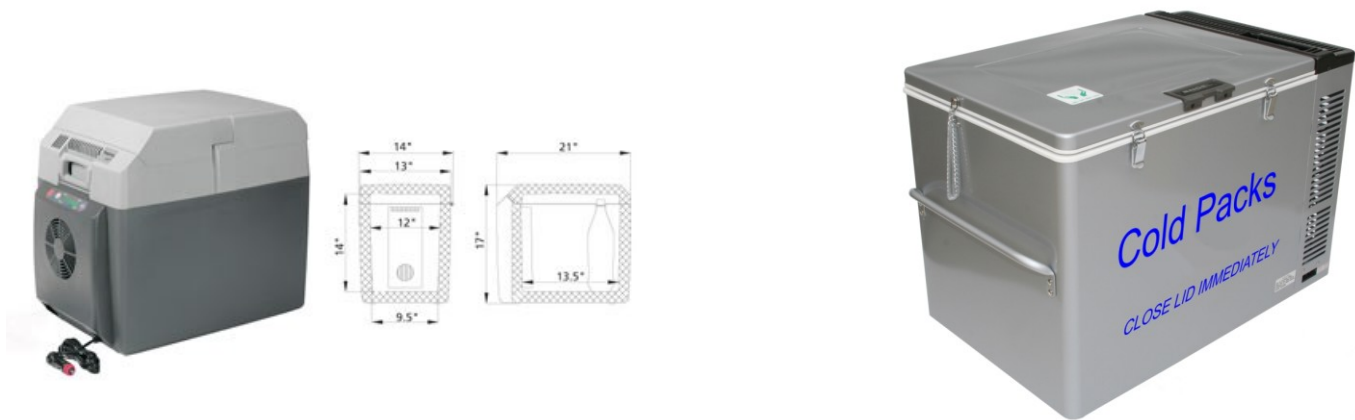

Our hardened-case, portable warmers and freezers make gel pack change out quick and hygienic. They are manufactured to extremely high standards of reliability and durability - it can handle constant movement in vehicles, from job site to job site, and in industrial settings. They feature quick warming or cooling, accurate temperature control (digital thermometer), and work on 12v, 24v, 110v, and 220v power. They come with a 7' UL approved cord, allowing you to reach a central power point. They require very little maintenance and use the quietest, most efficient warming units or compressor available. Compressors are shock-mounted to survive transport. GelCool Systems equipment and products provide maximum ease of use for your staff and professionals.

TYPICAL USAGE AND MAINTENANCE OF GELCOOL GEL PACKS

GelCool Systems understands that each company will develop their own methods and guidelines for managing this product, but here are some simple suggestions to help you get started.

STORAGE AND USE

GelCool Systems gel packs are cooled in hardened, portable freezer (or warmed in a professional-grade warmer). You will find that you will vary the temperature setting based upon some environmental variables, such as ambient temperature, humidity level, and user preference. These are professional grade, highly reliable, portable freezers and warmers. They were selected for several important reasons, including reliability, portability, and serviceability. They have built-in digital thermometers/thermostats.

It will become apparent how warm or cold you want the gel packs based upon the feedback of your users. The gel in these packs will not freeze nor will the urethane deform or melt at usable temperatures (the packs will survive temperatures of over 200 degrees Fahrenheit). You should initially cool the packs to 42 degrees Fahrenheit (5.5 degrees Celsius), or warm them to 120 degrees in the winter (based upon outside temperature and humidity levels). The gel packs should be worn from the beginning of exposure to extreme temperatures. For optimum effective cooling, set the temperature on the freezer to 42 degrees Fahrenheit. The user's body should have no difficulty with this level of cooling. Medical research clearly shows this to be a safe and effective cooling temperature which will not have any negative implications such as vasoconstriction or ice burns.

PLEASE NOTE: You should advise your users that even though the gel packs will cool for 15 to 30 minutes, the user will perceive that cooling has ended within the first 2 minutes because his body will get used to the pack's temperature. The pack is still cooling and pulling heat from his head much faster than the air vents in the hard hat could cool.

CLEANING AND REPLACEMENT

GelCool Systems doesn't recommend placing our gel packs in washing machines. If they must be machine-washed, then only in a large drum washer, not a washer with a central agitator. Ideally, the gel packs should be disinfected by hand (sprayed with a Lysol-type disinfectant). This is a new product, so there isn't data about the useful life, but we expect around 6 months with wear and tear. The gel packs are sold with an unconditional 2 year warranty that covers breakage, but not wear and tear. They are manufactured by the same factory that makes the g-suits for U.S. Military pilots and we use an extremely high-grade plastic for the packs which all but alleviates breakage from normal usage. This is one of the most expensive commercially available plastics and it shows in the quality, reliability, and feel of our products.

INSERTION/REMOVAL FROM HELMET

It is generally easier to insert the back of the gel pack into the back of the hard hat first, but insertion or removal can be accomplished starting at either end of the gel pack:

